

堆積高度(STACK HEIGHT)=10.1±1mm

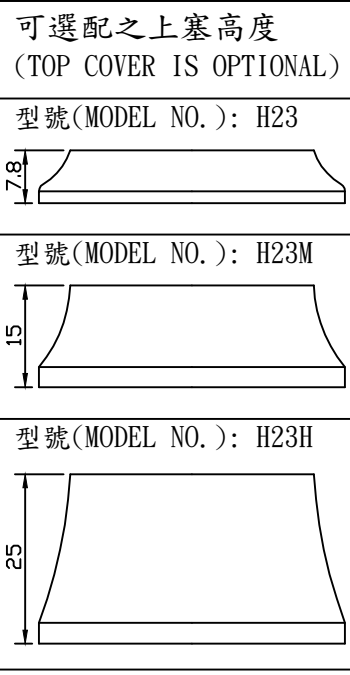

NO.	零件名稱 PART NAME	材質 MATERIAL	圖號 DRAWING NO.	台量 Q'TY	尺寸 DIM. DESCRIPTION
1	O形圈 O-RING	橡膠 NBR	120-8	1	ID28.5xØ2
2	鋁上塞 TOP COVER	鋁合金 6061/T6	23-3	1	1-1/8"
3	防塵蓋 UPPER WATER SEAL	橡膠 NBR	51-0	1	
4	鋁斜管 COMPRESSION RING	鋁合金 6061/T6	773-2	1	1-1/8"
5	密封式軸承 AC SEALED BEARING	軸承鋼 SUJ2	NHB-5D	2	OD41x36°x45°
6	鋁下塞 CROWN RACE	鋁合金 7075/T6	123-6	1	Ø30

- 全隱藏式車頭碗組
- 1-1/8" (28.6mm) 無牙式前叉立管
- 車頭管外徑=45mm [建議值]
- 鋁合金(6061)上塞
- 鋁合金(7075)下塞
- 斜接觸角度密封軸承

- Full-integrated headset
- For 1-1/8" threadless steerer
- Headtube OD. = 45mm
- 6061/T6 cnc machined top cover with seals
- 7075/T6 cnc machined crown race
- Angular contact sealed bearings

單位 UNIT	mm	比例 SCALE	1:1	日期 DRAWING DATE	2016.07.14	角法 VIEW	
型號 ITEM NO.	NECO H23/H23M/H23H						版次(REV):A
品名 ITEM NAME	H23/H23M/H23H 組立圖(Assembly Drawing)						
規格 DIMENSION	1-1/8" x41.2x30						
圖號 FIG. NO.	H23(H23M/H23H)-組立圖-A						
編號 NO.	更改內容(MODIFIED RECORD)		更改者 MODIFIER	修改日期 MODIFIED DATE			
製圖 DRAWER	何明諭	核准 PROOFREAD	核准 APPROBATION				
誌慶工業股份有限公司							